

Characterised control valves, 3-way, with internal thread

- For closed cold and warm water systems
- For modulating water-side control of AHU and heating systems
- Air bubble-tight (control path A - AB)

Overview of types

Type	kvs [m³/h]	DN [mm]	Rp [“]	ps [kPa]	n(gl)	Sv min.
R3015-P25-S1	0.25	15	1/2	1600	3.2	50
R3015-P4-S1	0.4	15	1/2	1600	3.2	50
R3015-P63-S1	0.63	15	1/2	1600	3.2	50
R3015-1-S1	1	15	1/2	1600	3.2	50
R3015-1P6-S1	1.6	15	1/2	1600	3.2	50
R3015-2P5-S1	2.5	15	1/2	1600	3.2	50
R3015-4-S1	4	15	1/2	1600	3.2	100
R3020-4-S2	4	20	3/4	1600	3.2	100
R3020-6P3-S2	6.3	20	3/4	1600	3.2	100
R3025-6P3-S2	6.3	25	1	1600	3.2	100
R3025-10-S2	10	25	1	1600	3.2	100
R3032-16-S3	16	32	1 1/4	1600	3.2	100
R3040-16-S3	16	40	1 1/2	1600	3.2	100
R3040-25-S4	25	40	1 1/2	1600	3.2	100
R3050-25-S4	25	50	2	1600	3.2	100
R3050-40-S4	40	50	2	1600	3.2	100
R3050-58-S4	58	50	2	1600	3.2	100

Technical data

Functional data	Media	Cold and hot water, water with glycol up to max. 50% vol.
Medium temperature		-10 °C ... 120 °C
Medium temperature note		The allowed media temperature can be limited, depending on the type of actuator. The correct values can be found in the respective actuator sheets.
Closing pressure Δps		1400 kPa
Differential pressure Δp_{max}		350 kPa
Differential pressure note		(200 kPa for low-noise operation)
Flow characteristic		Control path A – AB: equal percentage (in accordance with VDI/VDE 2178)
Leakage rate		Control path A – AB A, Air bubble-tight (EN 12266-1)
Leakage class		Bypass B – AB Leakage Class I (DIN EN 1349 and DIN EN 60534-4) 1 ... 2% of kvs, in relation to the highest value within the DN
Pipe connectors		Internal thread in accordance with ISO 7/1
Angle of rotation with limitation		90 ° (operating range control path A – AB 15 ... 90°, bypass B – AB 15 ... 70°)
Installation position		Upright to horizontal (in relation to the spindle)
Maintenance		Maintenance-free

Technical data

Materials	Valve	Forged, nickel-plated brass body
	Valve cone	Stainless steel
	Spindle	Stainless steel
	Stem seal	O-ring EPDM
	Valve seat	PTFE, O-Ring EPDM (DN20 Viton)
	Characterising disk	Path A-AB: DN15 ... DN50 TEFZEL (R3040-25-S4, R3050-40-S4, R3050-58-S4: Stainless Steel)

Safety notes

- The ball valve has been designed for use in stationary heating, ventilation and air-conditioning systems and is not allowed to be used outside the specified field of application, especially in aircraft or in any other airborne means of transport.
- Only authorised specialists may carry out installation. All applicable legal or institutional installation regulations must be complied with during installation.
- The ball valve does not contain any parts that can be replaced or repaired by the user.
- The ball valve may not be disposed of as household refuse. All locally valid regulations and requirements must be observed.
- When determining the flow rate characteristic of controlled devices, the recognised directives must be observed.

Product features

Principle of operation	The characterised control valve is adjusted by a rotary actuator. The actuator is controlled by a commercially available modulating or 3-point control system and moves the ball of the valve – the throttling device – to the position dictated by the positioning signal. Open the characterised control valve counterclockwise and close it clockwise.
Flow characteristic	Equal percentage flow control is ensured by the integrated characterising disk.
Recommended installation positions	The ball valve can be installed upright to horizontal. The ball valve may not be installed in a hanging position, i.e. with the spindle pointing downwards.

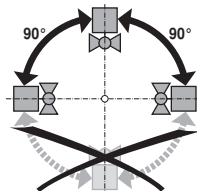

Water quality requirements	The water quality requirements specified in VDI 2035 must be adhered to. Characterised control valves are regulating devices. The use of dirt filters is recommended in order to prolong their service life as modulating instruments.
Maintenance	Ball valves and rotary actuators are maintenance-free. Before any kind of service work is carried out on the actuator, it is essential to isolate the rotary actuator from the power supply (by unplugging the electrical cable). Any pumps in the part of the piping system concerned must also be switched off and the appropriate slide valves closed (allow everything to cool down first if necessary and reduce the system pressure to ambient pressure level). The system must not be returned to service until the characterised control valve and the rotary actuator have been properly reassembled in accordance with the instructions and the pipeline has been refilled in the proper manner.
Flow direction	The direction of flow, specified by an arrow on the housing, is to be complied with, since otherwise the ball valve could become damaged. Please ensure that the ball is in the correct position (marking on the spindle).

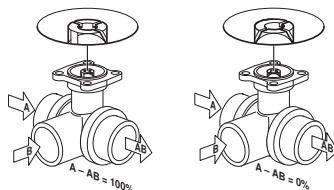

Accessories

	Description	Data sheet name
Mechanical accessories	Pipe connector for characterised control valve DN 15	ZR2315
	Pipe connector for characterised control valve DN 20	ZR2320
	Pipe connector for characterised control valve DN 25	ZR2325
	Pipe connector for characterised control valve DN 32	ZR2332
	Pipe connector for characterised control valve DN 40	ZR2340
	Pipe connector for characterised control valve DN 50	ZR2350

Dimensions / Weight

Dimensional drawings

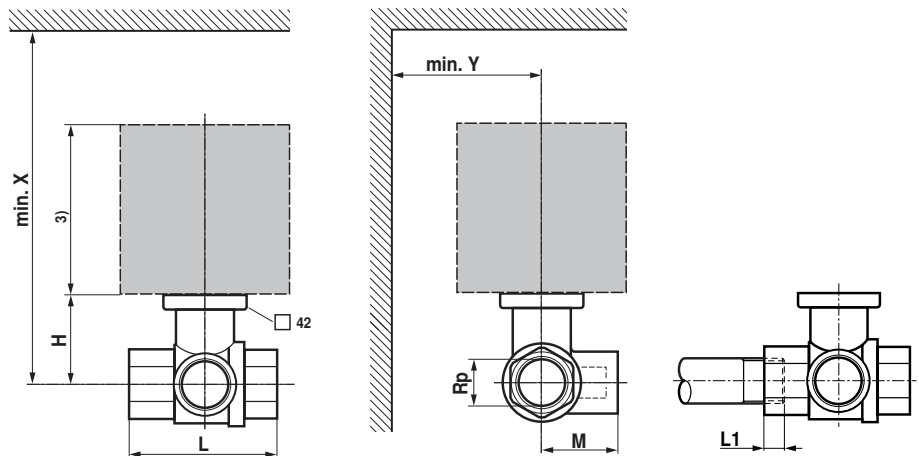

DN	Type	Weight approx. [kg]	Rp ["]	L [mm]	L1 [mm]	H [mm]	M [mm]	X [mm]	Y [mm]
15	R3015-P25-S1	0.27	1/2	67	13	35	36	230	90
15	R3015-P4-S1	0.27	1/2	67	13	35	36	230	90
15	R3015-P63-S1	0.27	1/2	67	13	35	36	230	90
15	R3015-1-S1	0.27	1/2	67	13	35	36	230	90
15	R3015-1P6-S1	0.37	1/2	67	13	44	36	230	90
15	R3015-2P5-S1	0.37	1/2	67	13	44	36	230	90
15	R3015-4-S1	0.37	1/2	67	13	44	36	230	90
20	R3020-4-S2	0.46	3/4	78	14	46	41.5	220	90
20	R3020-6P3-S2	0.46	3/4	78	14	46	41.5	220	90
25	R3025-6P3-S2	0.65	1	87	16	46	45	235	90
25	R3025-10-S2	0.65	1	87	16	46	45	235	90
32	R3032-16-S3	0.95	1 1/4	105	19	50.5	55.5	240	90
40	R3040-16-S3	1.15	1 1/2	111	19	50.5	56	240	90
40	R3040-25-S4	1.15	1 1/2	122	19	62	66.5	250	90
50	R3050-25-S4	1.9	2	125	22	56	68	245	90
50	R3050-40-S4	1.8	2	142	22	68	79	262	90
50	R3050-58-S4	1.8	2	142	22	68	79	262	90

L1: Maximum screwing depth.

X/Y: Minimum distance with respect to the valve centre.

The actuator dimensions can be found on the respective actuator data sheet.

Further documentation

- Complete overview «The complete product range of water solutions»
- Data sheets actuators
- Installation instructions for actuators and/or ball valves, respectively
- Notes for project planning (hydraulic characteristic curves and hydronic circuits, installation instructions, commissioning, maintenance, etc.)

R2..-S..



R3..-S..

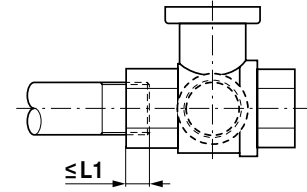
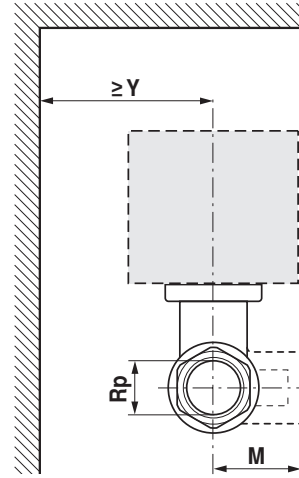
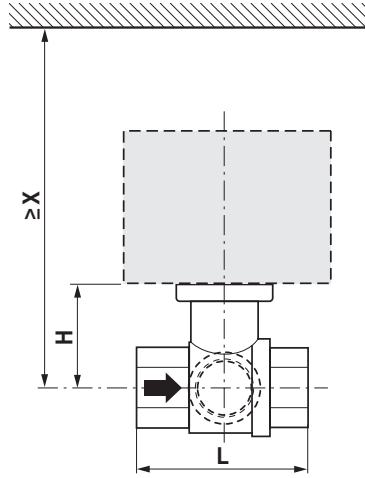

71270-00001.B



t -10 ... +120 °C		p _s 1600 kPa																									
		DN	Rp	mm				80 °C		100 °C		120 °C				100 °C		120 °C									
				L	H	M	L1	KR..		TR..		LR..A		NR..A		SR..A		TRF..		LRF..		NRF..A		SRF..A			
mm	”	mm	”	L	H	M	L1	X	Y	X	Y	X	Y	X	Y	X	Y	X	Y	X	Y	X	Y	X	Y		
R2015..-S1	R3015..-S1	15	1/2”	67	44	36	13	150	75	185	75	195	75	230	80	230	80	190	80	200	90	220	90	220	90		
R2020..-S2	R3020..-S2	20	3/4”	78	46	41.5	14					200	75	235	80	235	80			205	90	225	90	225	90		
R2025..-S2	R3025..-S2	25	1”	87	46	45	16					200	75	235	80	235	80			205	90	225	90	225	90		
R2032..-S3	R3032..-S3	32	1 1/4”	105	50.5	55.5	19							240	80	240	80					230	90	230	90		
R2040..-S3	R3040..-S3	40	1 1/2”	111	50.5	56	19							240	80	240	80					230	90	230	90		
	R3040-25-S4	40	1 1/2”	122	62	66.5	19									250	80							240	90		
R2050..-S4	R3050..-S4	50	2”	125	56	68	22									245	80							235	90		
	R3050-40-S4 R3050-58-S4	50	2”	142	68	79	22									262	80							252	90		

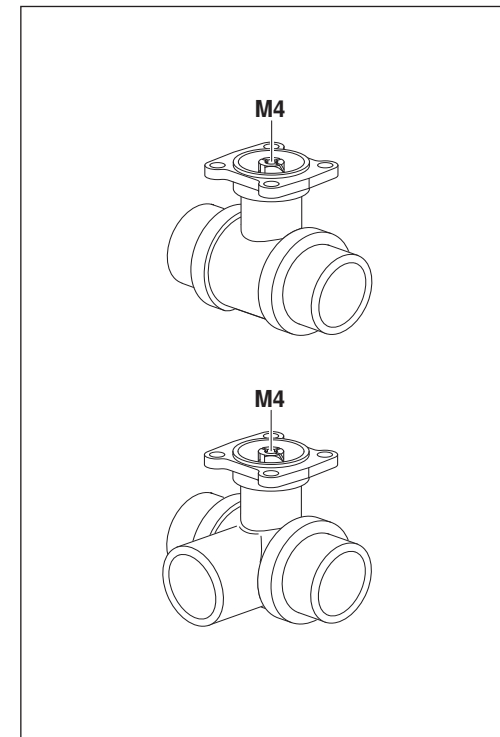
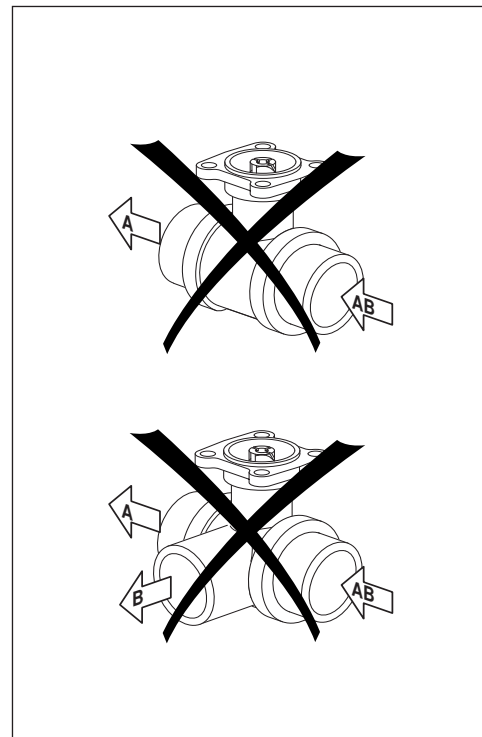
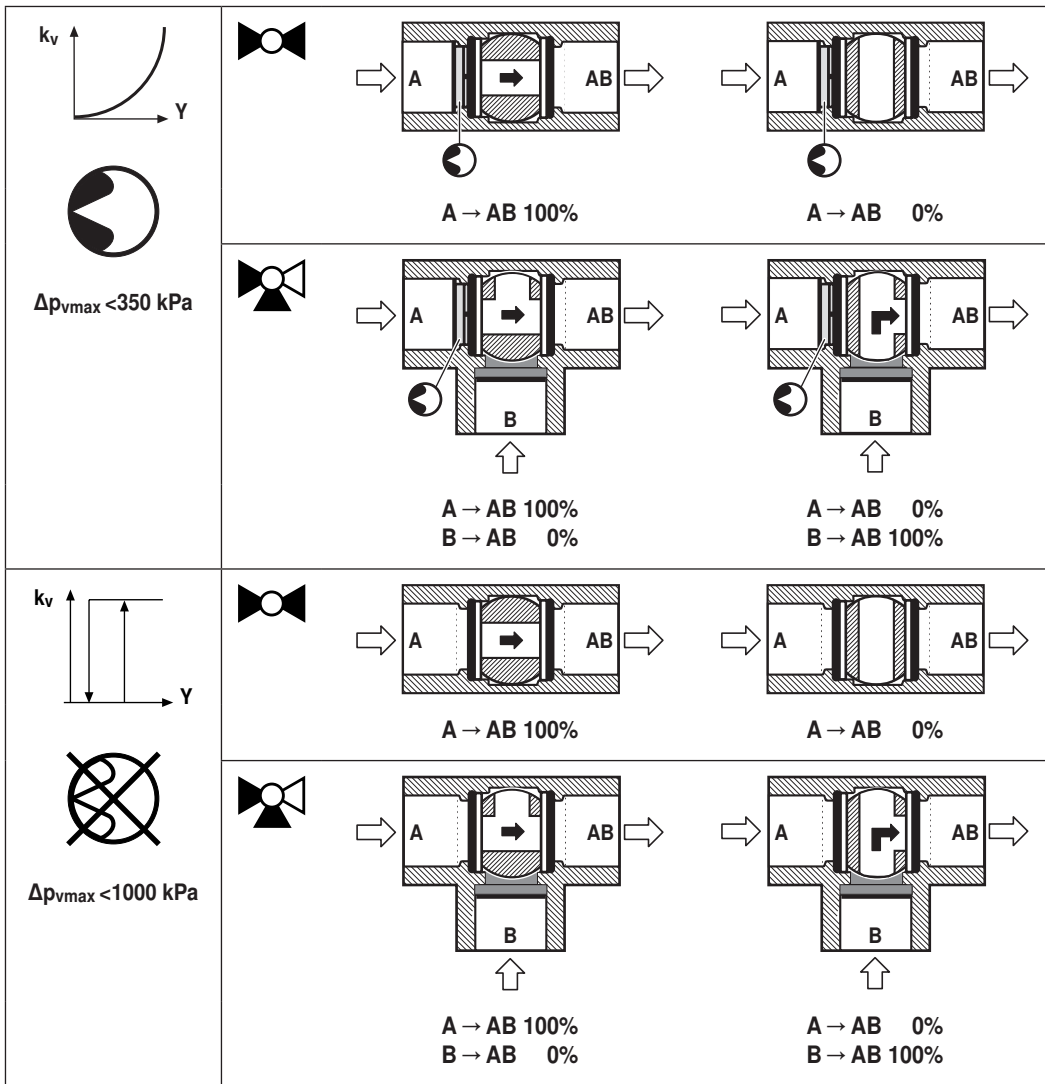

	A → AB 100%	A → AB 0%
	B → AB 0%	B → AB 100%

