

Globe valves, 3-way, with PN 16 flange

- For closed cold and warm water systems
- For modulating water-side control of air purification and heating systems

Type overview

Type	kvs [m ³ /h]	DN	Stroke [mm]	ps [kPa]	Sv min.
H711N	0.63	15	15	1600	50
H712N	1	15	15	1600	50
H713N	1.6	15	15	1600	50
H714N	2.5	15	15	1600	50
H715N	4	15	15	1600	50
H720N	6.3	20	15	1600	100
H725N	10	25	15	1600	100
H732N	16	32	15	1600	100
H740N	25	40	15	1600	100
H750N	40	50	15	1600	100
H764N	58	65	18	1600	100
H765N	63	65	30	1600	100
H779N	90	80	18	1600	100
H780N	100	80	30	1600	100
H7100N	145	100	30	1600	100
H7125N	220	125	40	1600	100
H7150N	320	150	40	1600	100

Technical data

Functional data	Media	Cold and hot water, water with glycol up to max. 50% vol.
	Medium temperature	5°C...120°C
	Medium temperature note	-10°C with spindle heating
	Flow characteristic	Control path A – AB: equal percentage (VDI/VDE 2173) n(gl) = 3, optimised in the opening range, Bypass B – AB: linear (VDI/VDE 2173)
	Leakage rate	Control path A – AB: Leakage Class III (DIN EN 1349 and DIN EN 60534-4) Bypass B – AB: max. 1% of the kvs value
	Pipe connections	Flange according to ISO 7005-2 (PN 16)
	Closing point	Top (▲)
	Installation position	Upright to horizontal (in relation to the stem)
	Maintenance	Maintenance-free
	Materials	Valve
Valve cone		stainless steel
Stem		stainless steel
Stem seal		EPDM O-ring
Sitz		GG25 / Niro (Bypass)

Safety notes

- The valve has been designed for use in stationary heating, ventilation and air conditioning systems and is not allowed to be used outside the specified field of application, especially in aircraft or in any other airborne means of transport.
- Only authorised specialists may carry out installation. All applicable legal or institutional installation regulations must be complied with during installation.
- The valve does not contain any parts that can be replaced or repaired by the user.

Safety notes

- The valve may not be disposed of as household refuse. All locally valid regulations and requirements must be observed.
- When determining the flow rate characteristic of controlled devices, the recognised directives must be observed.

Product features

- Principle of operation** The globe valve is adjusted by a globe valve actuator. The actuators are controlled by a commercially available modulating or 3-point control system and move the valve cone, which acts as a mixing device, to the opening position dictated by the positioning signal.
- Flow characteristic** An equal percentage flow characteristic in the flow direction is produced by the profile of the valve cone. The bypass exhibits a linear characteristic curve.

Accessories

	Description	Type
Electrical accessories	Spindle heating DN 15-50 (45 W)	ZH24-1
	Spindle heating DN 65-100 (60 W)	ZH24-1-C
	Spindle heating DN 125-250 (60 W)	ZH24-1-D
Mechanical accessories	Blanked flange PN 16, to globe valve DN 15 with flange	ZH715
	Blanked flange PN 16, to globe valve DN 20 with flange	ZH720
	Blanked flange PN 16, to globe valve DN 25 with flange	ZH725
	Blanked flange PN 16, to globe valve DN 32 with flange	ZH732
	Blanked flange PN 16, to globe valve DN 40 with flange	ZH740
	Blanked flange PN 16, to globe valve DN 50 with flange	ZH750
	Blanked flange PN 16, to globe valve DN 65 with flange	ZH765
	Blanked flange PN 16, to globe valve DN 80 with flange	ZH780
	Blanked flange PN 16, to globe valve DN 100 with flange	ZH7100
	Blanked flange PN 16, to globe valve DN 125 with flange	ZH7125
Blanked flange PN 16, to globe valve DN 150 with flange	ZH7150	

Installation notes

- Recommended installation positions** The globe valves may be mounted upright to horizontal. It is not permissible to mount the globe valves with the stem pointing downwards.

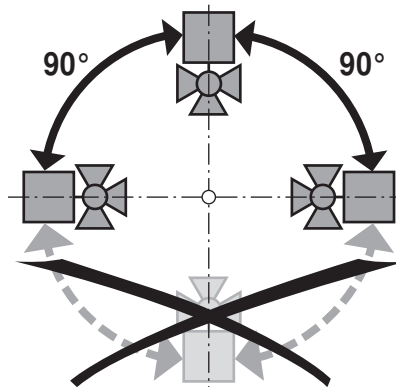

- Water quality requirements** The water quality requirements specified in VDI 2035 must be adhered to. Globe valves are regulating devices. The use of dirt filters is recommended in order to prolong their service life as modulating instruments.
- Maintenance** Globe valves and globe valve actuators are maintenance-free. Before any kind of service work is carried out on the actuator, it is essential to isolate the globe valve actuator from the power supply (by disconnecting the electrical cables if necessary). Any pumps in the part of the piping system concerned must also be switched off and the appropriate isolating valves closed (allow everything to cool down first if necessary and reduce the system pressure to ambient pressure level). The system must not be returned to service until the globe valve and the globe valve actuator have been mounted properly in accordance with the instructions and the pipelines have been refilled in the proper manner.

Installation notes

Flow direction The direction of flow, specified by an arrow on the housing, is to be complied with, since otherwise the valve could become damaged.

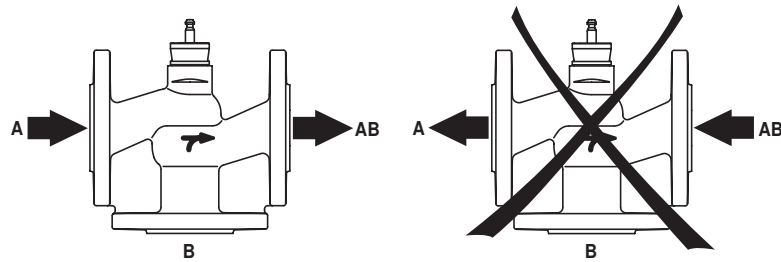

Dimensions [mm] / weight

Dimensional drawings

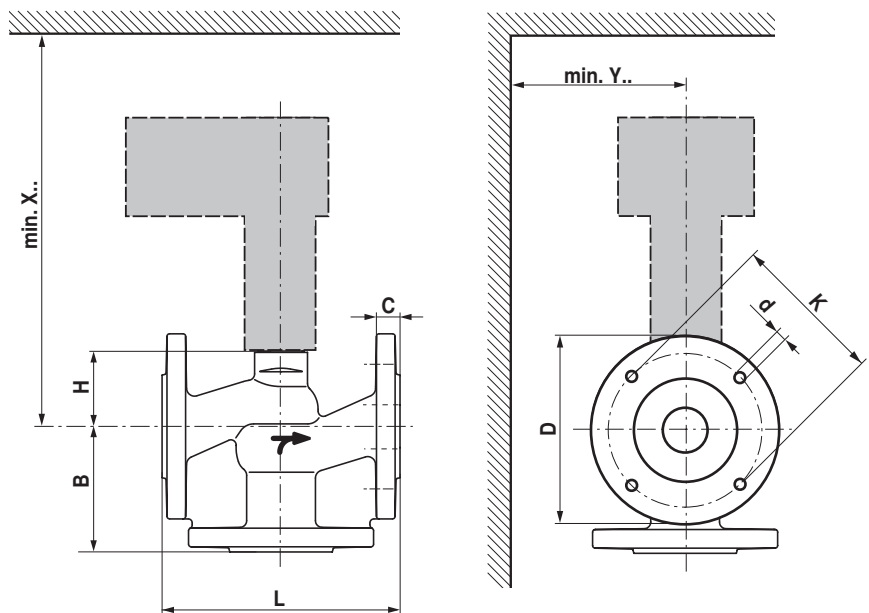

X/Y: Minimum distance with respect to the valve centre.
The actuator dimensions can be found on the respective actuator data sheet.

Type	DN	L [mm]	B [mm]	H [mm]	C [mm]	D [mm]	d [mm]	K [mm]	X [mm]	Y [mm]	Weight approx. [kg]
H711N	15	130	65	46	14	95	4 x 14	65	290	100	2.8
H712N	15	130	65	46	14	95	4 x 14	65	290	100	2.8
H713N	15	130	65	46	14	95	4 x 14	65	290	100	2.8
H714N	15	130	65	46	14	95	4 x 14	65	290	100	2.8
H715N	15	130	65	46	14	95	4 x 14	65	290	100	2.8
H720N	20	150	70	46	16	105	4 x 14	75	290	100	3.7
H725N	25	160	75	52	16	115	4 x 14	85	300	100	4.7
H732N	32	180	95	56	18	140	4 x 18	100	300	100	7.2
H740N	40	200	100	64	18	150	4 x 18	110	310	100	9.2
H750N	50	230	100	64	20	165	4 x 18	125	310	100	12.2
H764N	65	290	120	100	20	185	4 x 18	145	350	100	19
H765N	65	290	120	100	20	185	4 x 18	145	450	150	19
H779N	80	310	130	110	22	200	8 x 18	160	360	150	24
H780N	80	310	130	110	22	200	8 x 18	160	460	150	24
H7100N	100	350	150	125	24	220	8 x 18	180	480	150	34
H7125N	125	400	200	281	26	250	8 x 18	210	640	150	54.4
H7150N	150	480	210	343	26	285	8 x 22	240	710	150	72.6

Further documentation

- Overview Valve-actuator combinations
- Data sheets for globe valve actuators
- Installation instructions for valves and/or globe valve actuators
- Notes for project planning, 2-way and 3-way globe valves

BELIMO

H6..N



H7..N

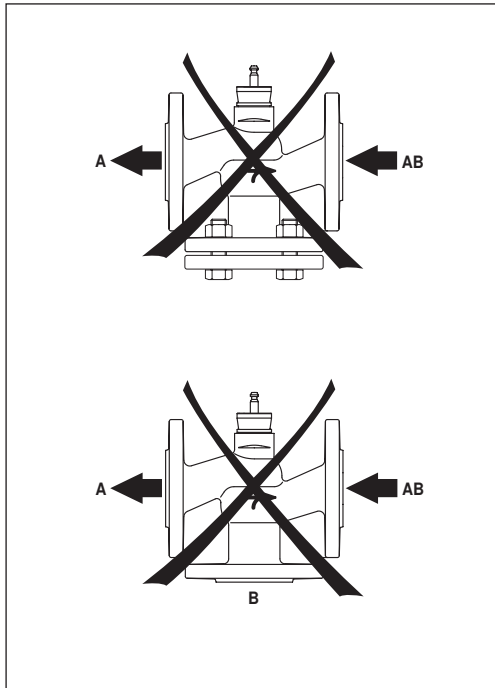
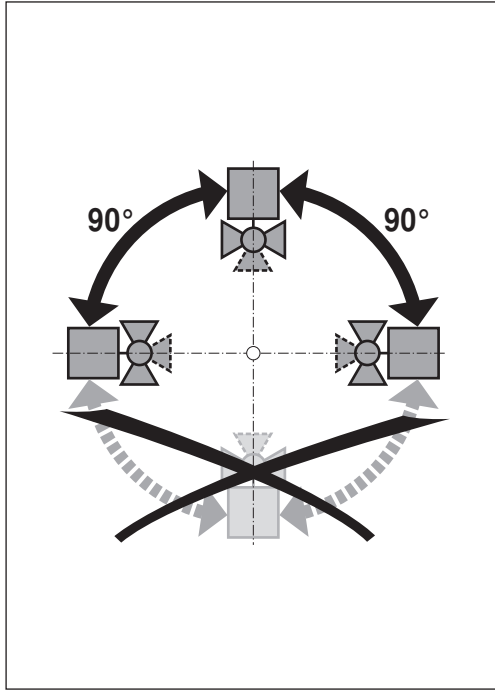

71555-00001.A



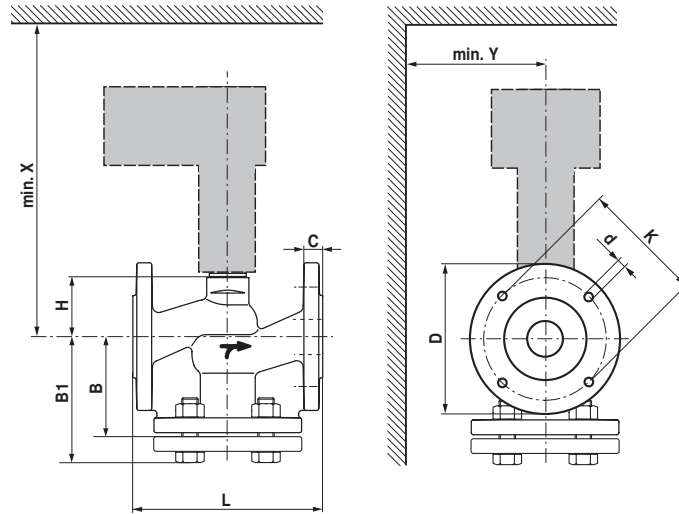

H6..N / H7..N

ps <1600 kPa (PN16) t= +5... +120°C		H6..N		H7..N		LV..A.. 500N		NV..A.. 1000N		SV..A.. 1500N		AVK..A.. 2000N		EV..A.. 2500N		RV..A.. 4500N									
DN	Hub / Stroke [mm]		B1 [mm]		B [mm]	Δps [kPa]	$\Delta pmax$ [kPa]	Δps [kPa]	$\Delta pmax$ [kPa]	Δps [kPa]	$\Delta pmax$ [kPa]	Δps [kPa]	$\Delta pmax$ [kPa]	Δps [kPa]	$\Delta pmax$ [kPa]	Δps [kPa]	$\Delta pmax$ [kPa]	L [mm]	H [mm]	D [mm]	K [mm]	d [mm]	C [mm]	X [mm]	Y [mm]
15	15	H611N ... 15N	89	H711N ... 15N	65	1300	400	1600	400	1600	400							130	46	95	65	4 x 14	14	290	100
20	15	H620N	96	H720N	70	900	400	1600	400	1600	400							150	46	105	75	4 x 14	16	290	100
25	15	H625N	101	H725N	75	500	400	1300	400	1600	400							160	52	115	85	4 x 14	16	300	100
32	15	H632N	123	H732N	95	350	350	1000	400	1600	400							180	56	140	100	4 x 18	18	300	100
40	15	H640N	128	H740N	100	150	150	500	400	900	400							200	64	150	110	4 x 18	18	310	100
50	15	H650N	130	H750N	100	70	70	300	300	550	400							230	64	165	125	4 x 18	20	310	100
65	18	H664N	150	H764N	120			140	140	280	280							290	100	185	145	4 x 18	20	350	100
65	30	H665N	150	H765N	120							400	400	550	400	1100	400	290	100	185	145	4 x 18	20	450	150
80	18	H679N	162	H779N	130			80	80	160	160							310	110	200	160	8 x 18	22	360	150
80	30	H680N	162	H780N	130							250	250	350	350	700	400	310	110	200	160	8 x 18	22	460	150
100	30	H6100N	182	H7100N	150							150	150	200	200	450	400	350	125	220	180	8 x 18	24	480	150
125	40			H7125N	200									130	130	290	290	400	281	250	210	8 x 18	26	640	150
150	40			H7150N	210									80	80	190	190	480	343	285	240	8 x 22	26	710	150