

FX07 Field Controller

The FX07 is a high performance field controller designed specifically for commercial Heating, Ventilating, Air Conditioning, and Refrigeration (HVACR) applications.

The FX07 supports 17 physical inputs and outputs including a wide range of sensors and actuating devices. The FX07 includes an onboard real-time clock to support the start/stop scheduling of equipment, real-time based control sequences, and time stamping of events and trend records.

With the optional integral user interface, you can locally monitor and adjust the FX07's operation. The FX07 also supports a panel- or wall-mountable Medium User Interface (MUI) for remote monitoring and adjustment.

The FX07 can be fitted with an N2 Open, LONWORKS®, or BACnet® communication card to integrate the controller into a compatible Building Automation System (BAS). Alternatively, the FX07 can be fitted with an RS-232C serial communication card to transmit event notification messages via Short Messaging Service (SMS) through a Global System for Mobile (GSM) modem.

Using the FX Tools software package, you can program the FX07 field controller to operate a wide variety of commercial HVACR equipment; including small refrigeration compressors, close control units, packaged rooftop units, fan coil units, unit ventilators, and chilling or heating ceiling beam installations.



Figure 1: FX07 Field Controller with Integral User Interface

Features and Benefits	
<input type="checkbox"/> Freely Programmable Controller	Is suitable for a wide range of HVAC or refrigeration control applications using the extensive programming features of the FX Tools software package.
<input type="checkbox"/> Network Communication Card Options: N2 Open, LONWORKS, and BACnet Protocols	Provide cost effective solution for stand-alone or networked applications.
<input type="checkbox"/> Remote Communication Services	Enable automatic reporting of events and alarms by SMS for stand-alone applications.
<input type="checkbox"/> Optional Integral Liquid Crystal Display (LCD) User Interface with Four Control Buttons	Provides onboard user access to the controlled system parameters using a custom designed display with two rows of alphanumeric characters and graphic icons with backlight.
<input type="checkbox"/> Optional Remote User Interface	Provides a clear presentation of control system data (including trend log data) on a menu driven and scrolling 4 line x 26 character LCD display with backlight.
Continued on next page . . .	

Features and Benefits (Cont.)

<ul style="list-style-type: none"> ❑ Analog Outputs with Pulse Width Modulated (PWM) Option ❑ Models with Various Output Configurations of Solid-State Triacs and Line Voltage Relays ❑ Network Room Module (NRM) 	<p>Provide an interface to a wide range of actuators and drives.</p> <p>Provide cost effective control of refrigeration, unitary, and terminal unit equipment.</p> <p>Features an internal temperature sensor and optional LCD display and dial, which allow the occupant to view and adjust the temperature setpoint value.</p>
---	--

Onboard Inputs and Outputs

You can connect up to 17 physical inputs and outputs to the FX07, including:

- four Analog Inputs (AIs) (software configurable)
 - A99 temperature
 - Ni 1000 (Johnson Controls) temperature
 - Pt 1000 temperature
 - NTC 10k temperature
 - Ratiometric (0.5-4.5 VDC)
 - 0-10 VDC
- five Digital (Binary) Inputs (DIs)
 - voltage free contacts
 - with pulse counter option
- six Digital (Binary) Outputs (DOs) (model dependent)
 - six relays (line voltage contacts)
 - two triacs (24 V), three interlocked relays, one free (high power) relay
 - two triacs (24 V), four free relays
- two Analog Outputs (AOs)
 - 0-10 VDC
 - PWM (100 Hz)

- keypad with four push buttons
- navigation menu to guide users

The integral user interface is fully configurable within the application design and typically provides:

- display of status information
- display and modification of setpoints
- display and modification of configuration parameters
- clearing and acknowledgement of active alarms
- background lighting with red color when an alarm condition exists

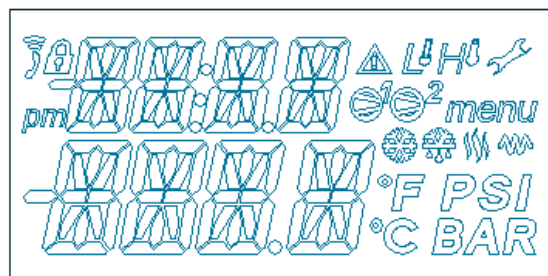

Figure 2: Detail of the LCD

Integral LCD User Interface

The optional integral LCD user interface (Figure 2) for the FX07 features:

- two display rows with four alphanumeric characters (13 segment)
- blue or red background light
- graphic status icons: compressor, alarm, high pressure, low pressure, maintenance, heat, cool, defrost, and electric heat symbols

Remote Medium User Interface

The FX07 also supports a remote medium user interface. The MUI has a 4 line x 26 character, backlit LCD screen, 6 push buttons, and 10 discrete status Light-Emitting Diodes (LEDs). See Figure 3. You can completely configure the MUI, including its navigation menu, within the FX07 application design. The mounting styles include:

- **Panel Mount:** Mounts up to 3 m (9.8 ft) from the FX07 controller. The FX07 powers and operates this user interface. A flat telephone cable connects the power supply and data communications to the FX07 controller.
- **Wall Mount:** Mounts up to 300 m (984 ft) from the FX07. The wall mount user interface must be independently powered with 24 VAC. The data communication requires a 3-wire shielded cable (not provided) for the connection from the remote display to the FX07 controller. You can also panel mount this unit.



Figure 3: Remote Medium User Interface

Communication Card Options

The FX07 can operate as a stand-alone controller, or it can be fitted with a communication card to provide various types of remote network access. The FX07 supports N2 Open, LONWORKS, BACnet Master Slave/Token-Passing (MS/TP), or RS-232C networking communication card options.

N2 Open Communication Card

When fitted with an N2 Open communication card, the FX07 controller can connect to the N2 bus of a compatible supervisory controller. This allows network access to its control system variables and parameters.

LONWORKS Communication Card

When fitted with a LONWORKS communication card, the FX07 can integrate into a LONWORKS network. This allows peer-to-peer communication with other LONWORKS compatible devices on the network and data access from a supervisory system.

BACnet MS/TP Communication Card

When fitted with a BACnet MS/TP communication card, the FX07 can connect to a BACnet compliant BAS. This allows network access to the FX07 control system variables and parameters. The FX07 controller supports peer-to-peer communication with other controllers on the BACnet network and change-of-value reporting to monitoring stations.

RS-232C Serial Communication Card

When fitted with an RS-232C serial communication card, the FX07 can connect to a Global System for Mobile (GSM) modem. When an application event goes into the active or alarm state, the FX07 sends out text messages in SMS format to a prioritized list of destinations, such as to a telephone service center or directly to a mobile telephone.

Real-Time Control

The FX07 controller has an embedded real-time clock that supports real-time control functions such as the display of time and date on the user interface, scheduling, and event and trend management. The real-time clock continues to run for at least 10 days without power at room temperature.

Scheduling

The real-time clock enables the time scheduling of start and stop commands and occupancy mode changes to the equipment being monitored and controlled. You can configure scheduled commands to execute on one or more days of the week. An exception day calendar allows for alternative time schedules on holidays or during special periods in the year. You can also display and edit time schedules on the integral or remote user interface.

Event Management

The real-time clock enables the time stamping of alarm and event records. You can configure the FX07 controller to detect and display events and alarms associated with up to 20 data points or variables in the control application.

Application events indicate to users that the controlled equipment requires attention or that the controlled conditions are not within the expected limits. Examples of alarms include:

- analog value is outside of a desired range
- status value represents a condition that is not normal

You can view, acknowledge, or clear active alarms via the integral or remote user interface. You can view the event logs on the remote user interface. You can also view the event logs via a supervisory system.

Trend Management

The real-time clock enables the time stamping of trend records. You can configure the FX07 to record the values of up to four points at intervals between 1 minute and 1 day. You can then view the values and times on the remote user interface.

Room Command Modules

Two series of room command modules are available for use with the FX07 controllers: the TM Series room command modules and the network room modules.

TM Series Room Command Modules

The TM Series room command module (Figure 4) features an internal temperature sensor and an optional dial that allows the occupant to adjust the temperature setpoint value or request a warmer or cooler setpoint. Certain models also have a dial to enable the occupant to override the speed of a three-speed fan.

The operation of the push button and LED are configurable within the application. Typically, the push button initiates a temporary occupancy period (for example, at night or weekends), and the LED provides occupancy status indication.



Figure 4: TM Series Room Command Module

The TM Series room command module for North America has a 120 x 80 mm (4.72 x 3.15 in.) enclosure and has dual temperature units (°F and °C).

Network Room Modules

The NRM (Figure 5) is an intelligent device that communicates with the FX07 via the serial display bus. The NRM features an internal temperature sensor and optional LCD display and dial, which allow the occupant to view and adjust the temperature setpoint value. Certain models also have a fan button, which allows the occupant to override the speed of a three-speed fan. The override status of the fan appears on the LCD display.

The NRM also enables the initiation of a temporary occupancy period (for example, at night or weekends), and you can configure the LCD to blink when the controller is not in the occupied mode.

The North American NRMs have an additional button that allows you to select the units on the temperature display (°F or °C). These modules are available in the 120 x 80 mm (4.72 x 3.15 in.) enclosure.



Figure 5: Network Room Modules (NRMs)

FX Tools Software

Use the FX Tools software suite to program, download, test, and commission the FX devices, including the FX07. The FX Tools software is available on CD in two versions: FX Tools Pro and FX Tools Express (North America only).

FX Tools Pro CD includes:

- FX Builder – used to program an FX07. FX Builder provides complete flexibility in programming the FX07.
- FX CommPro N2 – used to download, test, and commission an FX07 on an N2 Open network
- FX CommPro LON – used to download, test, and commission an FX07 on a LONWORKS network
- FX CommPro BACnet software – used to download, test, and commission an FX07 on a BACnet network.
- FX Builder Express (North America only) – used to select an FX07 standard application and configure it using graphical plug-ins.

The FX Tools Express CD (North America only) does not include FX Builder.

Programming Key

You can download the application to the FX07 controller via a computer with FX CommPro, or via the FX Programming Key (Figure 6) (except LON versions).



Figure 6: Programming Key

IMPORTANT: Use this FX07 controller only as an operating control. Where failure or malfunction of the FX07 could lead to personal injury or damage to the controlled equipment or other property, additional precautions must be designed into the control system. Incorporate and maintain other devices such as supervisory or alarm systems or safety or limit controls that are intended to warn of, or protect against, failure or malfunction of the FX07 controller.

FX07 Field Controller Dimensions

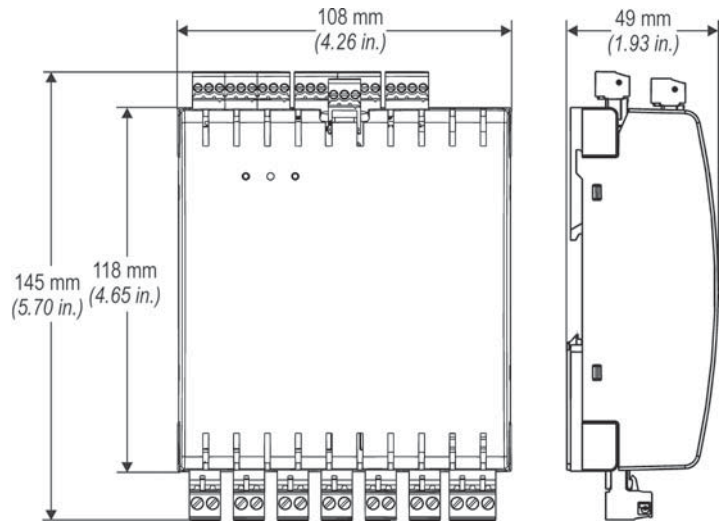

Figure 7: FX07 Controller Dimensions

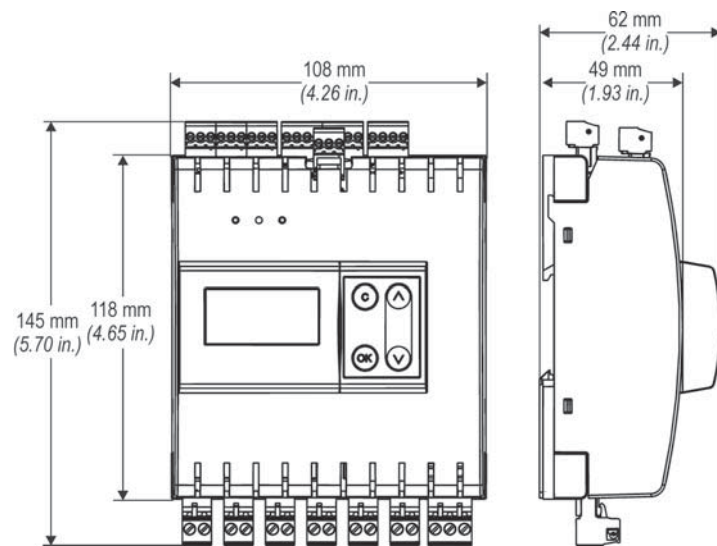

Figure 8: FX07 Controller with Display Dimensions

Network Room Module Dimensions

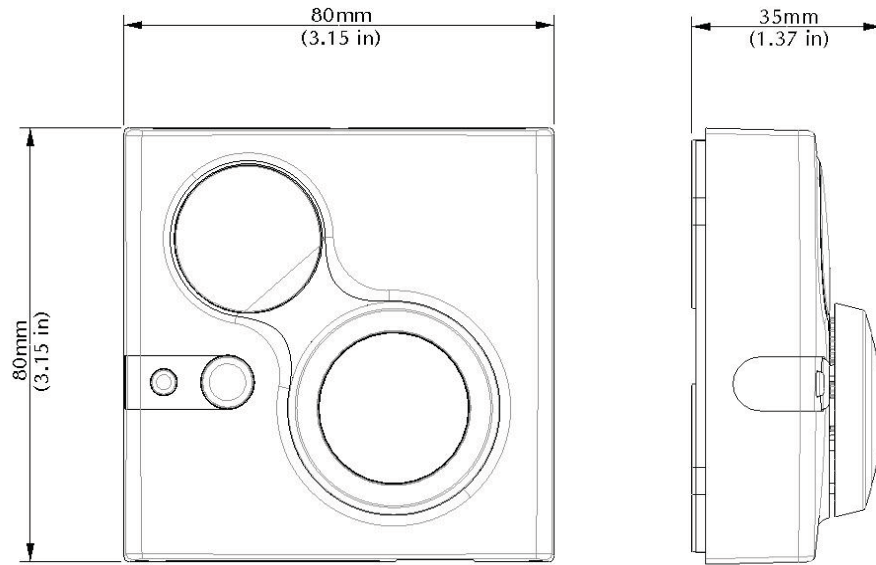

Figure 9: Network Room Module Dimensions

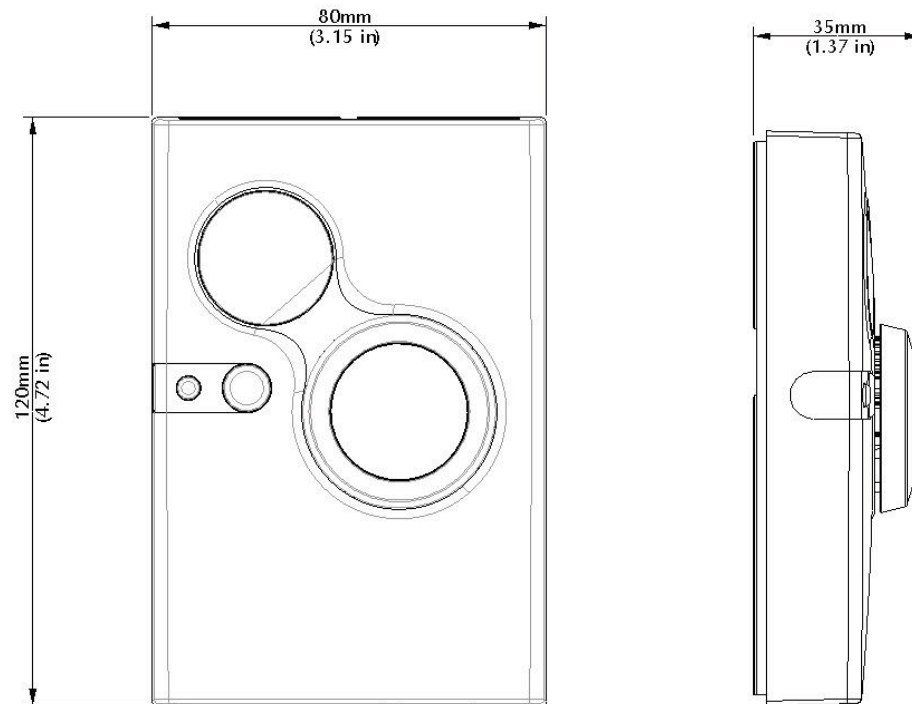

Figure 10: Network Room Module Dimensions
(North America Models)

Ordering Codes

Table 1 through Table 12 give ordering information for the FX07 Controllers, FX07 Accessories, Room Command Modules, and Configuration Software.

Table 1: FX07 Controller Ordering Information (24 VAC Power Supply, without Integral Display)

Product Code Number	Description
LP-FX07D00-000C	FX07 Controller: 4 AIs, 5 DIs, 2 AOs (0-10 V or PWM), 6 DOs (Relays), no communication card
LP-FX07D01-000C	FX07 Controller: 4 AIs, 5 DIs, 2 AOs (0-10 V or PWM), 6 DOs (Relays), N2 Open card
LP-FX07D02-000C	FX07 Controller: 4 AIs, 5 DIs, 2 AOs (0-10 V or PWM), 6 DOs (Relays), LONWORKS card
LP-FX07D03-000C	FX07 Controller: 4 AIs, 5 DIs, 2 AOs (0-10 V or PWM), 6 DOs (Relays), RS-232C card
LP-FX07D04-000C	FX07 (Rev. A): 4 AIs, 5 DIs, 2 AOs (0-10 V or PWM), 6 DOs (Relays), BACnet card
LP-FX07D20-000C	FX07 Controller: 4 AIs, 5 DIs, 2 AOs (0-10 V), 6 DOs (4 Relays, 2 Triacs), no communication card
LP-FX07D21-000C	FX07 Controller: 4 AIs, 5 DIs, 2 AOs (0-10 V), 6 DOs (4 Relays, 2 Triacs), N2 Open card
LP-FX07D22-000C	FX07 Controller: 4 AIs, 5 DIs, 2 AOs (0-10 V), 6 DOs (4 Relays, 2 Triacs), LONWORKS card
LP-FX07D23-000C	FX07 Controller: 4 AIs, 5 DIs, 2 AOs (0-10 V), 6 DOs (4 Relays, 2 Triacs), RS-232C card
LP-FX07D24-000C	FX07 (Rev. A): 4 AIs, 5 DIs, 2 AOs (0-10 V), 6 DOs (4 Relays, 2 Triacs), BACnet card
LP-FX07D30-000C	FX07 Controller: 4 AIs, 5 DIs, 2 AOs (0-10 V), 6 DOs (3 Interlocked Relays, 1 Free Relay, 2 Triacs), no communication card
LP-FX07D31-000C	FX07 Controller: 4 AIs, 5 DIs, 2 AOs (0-10 V), 6 DOs (3 Interlocked Relays, 1 Free Relay, 2 Triacs), N2 Open card
LP-FX07D32-000C	FX07 Controller: 4 AIs, 5 DIs, 2 AOs (0-10 V), 6 DOs (3 Interlocked Relays, 1 Free Relay, 2 Triacs), LONWORKS card
LP-FX07D33-000C	FX07 Controller: 4 AIs, 5 DIs, 2 AOs (0-10 V), 6 DOs (3 Interlocked Relays, 1 Free Relay, 2 Triacs) RS-232C card
LP-FX07D34-000C	FX07 (Rev. A): 4 AIs, 5 DIs, 2 AOs (0-10 V), 6 DOs (3 Interlocked Relays, 1 Free Relay, 2 Triacs), BACnet card

Table 2: FX07 Controller Ordering Information (24 VAC Power Supply, with Integral Display)

Product Code Number	Description
LP-FX07D50-000C	FX07 Controller: 4 AIs, 5 DIs, 2 AOs (0-10 V or PWM), 6 DOs (Relays), no communication card
LP-FX07D51-000C	FX07 Controller: 4 AIs, 5 DIs, 2 AOs (0-10 V or PWM), 6 DOs (Relays), N2 Open card
LP-FX07D52-000C	FX07 Controller: 4 AIs, 5 DIs, 2 AOs (0-10 V or PWM), 6 DOs (Relays), LONWORKS card
LP-FX07D53-000C	FX07 Controller: 4 AIs, 5 DIs, 2 AOs (0-10 V or PWM), 6 DOs (Relays), RS-232C card
LP-FX07D54-000C	FX07 Controller: 4 AIs, 5 DIs, 2 AOs (0-10 V or PWM), 6 DOs (Relays), BACnet card
LP-FX07D70-000C	FX07 Controller: 4 AIs, 5 DIs, 2 AOs (0-10 V), 6 DOs (4 Relays, 2 Triacs), no communication card
LP-FX07D71-000C	FX07 Controller: 4 AIs, 5 DIs, 2 AOs (0-10 V), 6 DOs (4 Relays, 2 Triacs), N2 Open card
Continued on next page . . .	

Product Code Number (Cont.)	Description
LP-FX07D72-000C	FX07 Controller: 4 AIs, 5 DIs, 2 AOs (0-10 V), 6 DOs (4 Relays, 2 Triacs), LONWORKS card
LP-FX07D73-000C	FX07 Controller: 4 AIs, 5 DIs, 2 AOs (0-10 V), 6 DOs (4 Relays, 2 Triacs), RS-232C card
LP-FX07D74-000C	FX07 Controller: 4 AIs, 5 DIs, 2 AOs (0-10 V), 6 DOs (4 Relays, 2 Triacs), BACnet card
LP-FX07D80-000C	FX07 Controller: 4 AIs, 5 DIs, 2 AOs (0-10 V), 6 DOs (3 Interlocked Relays, 1 Free Relay, 2 Triacs), no communication card
LP-FX07D81-000C	FX07 Controller: 4 AIs, 5 DIs, 2 AOs (0-10 V), 6 DOs (3 Interlocked Relays, 1 Free Relay, 2 Triacs), N2 Open card
LP-FX07D82-000C	FX07 Controller: 4 AIs, 5 DIs, 2 AOs (0-10 V), 6 DOs (3 Interlocked Relays, 1 Free Relay, 2 Triacs), LONWORKS card
LP-FX07D83-000C	FX07 Controller: 4 AIs, 5 DIs, 2 AOs (0-10 V), 6 DOs (3 Interlocked Relays, 1 Free Relay, 2 Triacs) RS-232C card
LP-FX07D84-000C	FX07 Controller: 4 AIs, 5 DIs, 2 AOs (0-10 V), 6 DOs (3 Interlocked Relays, 1 Free Relay, 2 Triacs), BACnet card

Table 3: FX07 Controller Ordering Information (90 to 240 VAC Power Supply, without Integral Display, Not Available in North America)

Product Code Number	Description
LP-FX07A00-000C	FX07 Controller: 4 AIs, 5 DIs, 2 AOs (0-10 V or PWM), 6 DOs (Relays), no communication card
LP-FX07A01-000C	FX07 Controller: 4 AIs, 5 DIs, 2 AOs (0-10 V or PWM), 6 DOs (Relays), N2 Open card
LP-FX07A02-000C	FX07 Controller: 4 AIs, 5 DIs, 2 AOs (0-10 V or PWM), 6 DOs (Relays), LONWORKS card
LP-FX07A03-000C	FX07 Controller: 4 AIs, 5 DIs, 2 AOs (0-10 V or PWM), 6 DOs (Relays), RS-232C card
LP-FX07A04-000C	FX07 Controller: 4 AIs, 5 DIs, 2 AOs (0-10 V or PWM), 6 DOs (Relays), RS-232C card
LP-FX07A20-000C	FX07 Controller: 4 AIs, 5 DIs, 2 AOs (0-10 V), 6 DOs (4 Relays, 2 Triacs), no communication card
LP-FX07A21-000C	FX07 Controller: 4 AIs, 5 DIs, 2 AOs (0-10 V), 6 DOs (4 Relays, 2 Triacs), N2 Open card
LP-FX07A22-000C	FX07 Controller: 4 AIs, 5 DIs, 2 AOs (0-10 V), 6 DOs (4 Relays, 2 Triacs), LONWORKS card
LP-FX07A23-000C	FX07 Controller: 4 AIs, 5 DIs, 2 AOs (0-10 V), 6 DOs (4 Relays, 2 Triacs), RS-232C card
LP-FX07A24-000C	FX07 Controller: 4 AIs, 5 DIs, 2 AOs (0-10 V), 6 DOs (4 Relays, 2 Triacs), BACnet card
LP-FX07A30-000C	FX07 Controller: 4 AIs, 5 DIs, 2 AOs (0-10 V), 6 DOs (3 Interlocked Relays, 1 Free Relay, 2 Triacs), no communication card
LP-FX07A31-000C	FX07 Controller: 4 AIs, 5 DIs, 2 AOs (0-10 V), 6 DOs (3 Interlocked Relays, 1 Free Relay, 2 Triacs), N2 Open card
LP-FX07A32-000C	FX07 Controller: 4 AIs, 5 DIs, 2 AOs (0-10 V), 6 DOs (3 Interlocked Relays, 1 Free Relay, 2 Triacs), LONWORKS card
LP-FX07A33-000C	FX07 Controller: 4 AIs, 5 DIs, 2 AOs (0-10 V), 6 DOs (3 Interlocked Relays, 1 Free Relay, 2 Triacs) RS-232C card
LP-FX07A34-000C	FX07 Controller: 4 AIs, 5 DIs, 2 AOs (0-10 V), 6 DOs (3 Interlocked Relays, 1 Free Relay, 2 Triacs), BACnet card

Table 4: FX07 Controller Ordering Information (90 to 240 VAC Power Supply, with Integral Display, Not Available in North America)

Product Code Number	Description
LP-FX07A50-000C	FX07 Controller: 4 AIs, 5 DIs, 2 AOs (0-10 V or PWM), 6 DOs (Relays), no communication card
LP-FX07A51-000C	FX07 Controller: 4 AIs, 5 DIs, 2 AOs (0-10 V or PWM), 6 DOs (Relays), N2 Open card
LP-FX07A52-000C	FX07 Controller: 4 AIs, 5 DIs, 2 AOs (0-10 V or PWM), 6 DOs (Relays), LONWORKS card
LP-FX07A53-000C	FX07 Controller: 4 AIs, 5 DIs, 2 AOs (0-10 V or PWM), 6 DOs (Relays), RS-232C card
LP-FX07A54-000C	FX07 Controller: 4 AIs, 5 DIs, 2 AOs (0-10 V or PWM), 6 DOs (Relays), BACnet card
LP-FX07A70-000C	FX07 Controller: 4 AIs, 5 DIs, 2 AOs (0-10 V), 6 DOs (4 Relays, 2 Triacs), no communication card
LP-FX07A71-000C	FX07 Controller: 4 AIs, 5 DIs, 2 AOs (0-10 V), 6 DOs (4 Relays, 2 Triacs), N2 Open card
LP-FX07A72-000C	FX07 Controller: 4 AIs, 5 DIs, 2 AOs (0-10 V), 6 DOs (4 Relays, 2 Triacs), LONWORKS card
LP-FX07A73-000C	FX07 Controller: 4 AIs, 5 DIs, 2 AOs (0-10 V), 6 DOs (4 Relays, 2 Triacs), RS-232C card
LP-FX07A74-000C	FX07 Controller: 4 AIs, 5 DIs, 2 AOs (0-10 V), 6 DOs (4 Relays, 2 Triacs), BACnet card
LP-FX07A80-000C	FX07 Controller: 4 AIs, 5 DIs, 2 AOs (0-10 V), 6 DOs (3 Interlocked Relays, 1 Free Relay, 2 Triacs), no communication card
LP-FX07A81-000C	FX07 Controller: 4 AIs, 5 DIs, 2 AOs (0-10 V), 6 DOs (3 Interlocked Relays, 1 Free Relay, 2 Triacs), N2 Open card
LP-FX07A82-000C	FX07 Controller: 4 AIs, 5 DIs, 2 AOs (0-10 V), 6 DOs (3 Interlocked Relays, 1 Free Relay, 2 Triacs), LONWORKS card
LP-FX07A83-000C	FX07 Controller: 4 AIs, 5 DIs, 2 AOs (0-10 V), 6 DOs (3 Interlocked Relays, 1 Free Relay, 2 Triacs) RS-232C card
LP-FX07A84-000C	FX07 Controller: 4 AIs, 5 DIs, 2 AOs (0-10 V), 6 DOs (3 Interlocked Relays, 1 Free Relay, 2 Triacs), BACnet card

Table 5: FX07 Communication Card Ordering Information

Product Code Number	Description
LP-NET071-000C	N2 Open communication card for FX07
LP-NET072-000C	LONWORKS communication card for FX07
LP-NET073-000C	RS-232C communication card for FX07
LP-NET074-000C	BACnet communication card for FX07 Rev. A only

Table 6: FX07 Accessories Ordering Information

Product Code Number	Description
LP-KIT100-000C	FX Programming Key
DT-9100-8901	Power Supply Adapter for Programming Key: 230 VAC/12 VDC (Europe Only)
LP-KIT007-001C	Interface cable for standard landline modem, 1.5 m (4.9 ft)
LP-KIT007-002C	Interface cable for GSM modem, 1.5 m (4.9 ft)
LP-KIT007-013C	Null modem cable for computer connection, 3 m (9.8 ft)
LP-KIT007-014C	Null modem cable for computer connection, 15 m (49.2 ft)
Continued on next page . . .	

Product Code Number (Cont.)	Description
LP-KIT200-000C	N2 Commissioning Adapter: Includes port powered RS-232C to RS-485 converter, 3 m (10 ft) cable, and mating connectors for FX05, FX06, FX07, FX14, FX15, FX16, and FXVMA.
LP-KIT204-000C	BACnet Internet Protocol (IP) to MS/TP Adapter: Includes USB port powered Ethernet (IP) to RS-485 (MS/TP) converter, 3 m (10 ft) cable, and mating connectors for FX07, FX14, and FX16 controllers.
IU-9100-8401	Converter RS-232C/RS-485 (N2) 230 VAC (Europe only)
LP-KIT007-020C	Bag of replacement communication wiring connectors.
LP-KIT007-100C	Bag of replacement Input/Output (I/O) and power wiring connectors.

Table 7: TM Series Room Command Modules Ordering Information (80 x 80 mm [3.15 x 3.15 in.], °C, European Models)

Product Code Number	Description
TM-2140-0000	Room Command Module, temperature sensor only
TM-2150-0000	Room Command Module, occupancy button and LED
TM-2160-0000	Room Command Module, 12-28°C setpoint dial, occupancy button and LED
TM-2160-0002	Room Command Module, 12-28°C setpoint dial, occupancy button and LED, fan speed override
TM-2160-0005	Room Command Module, ± setpoint dial, occupancy button and LED
TM-2160-0007	Room Command Module, ± setpoint dial, occupancy button and LED, fan speed override
TM-2190-0000	Room Command Module, 12-28°C setpoint dial
TM-2190-0005	Room Command Module, ± setpoint dial

Table 8: Network Room Modules Ordering Information (Available in Europe)

Product Code	Features/Options						
	Size (mm)	Service Port Type	LCD Display	Temperature Adjustment Dial	Fan Speed Selector Button	°F/°C Button	Addressable
LP-NRM001-000C	80 x 80	Program Key	No	No	No	No	No
LP-NRM002-000C			Yes	Yes	No	No	No
LP-NRM003-000C			Yes	Yes	Yes	No	No
LP-NRM511-000C		MUI	No	No	No	No	Yes
LP-NRM502-000C			Yes	Yes	No	No	No
LP-NRM503-000C			Yes	Yes	Yes	No	No

Table 9: Software Ordering Information

Product Code Number	Description
LP-FXTPRO-0	FX Tools Pro CD (Includes the FX Builder, FX Builder Express, FX CommPro N2, LON, BACnet Software) - New User
LP-FXTPRO-6	FX Tools Pro CD (Includes the FX Builder, FX Builder Express, FX CommPro N2, LON, BACnet Software) - Upgrade

Table 10: TM Series Room Command Modules Ordering Information (120 x 80 mm [4.72 x 3.15 in.], °F/°C)

Product Code Number	Description
TM-2141-0000	Room Command Module, temperature sensor only
TM-2151-0000	Room Command Module, occupancy button and LED
TM-2161-0000	Room Command Module, 54-82°F/12-28°C setpoint dial, occupancy button and LED
TM-2161-0002	Room Command Module, 54-82°F/12-28°C setpoint dial, occupancy button and LED, fan speed override
TM-2161-0005	Room Command Module, ± setpoint dial, occupancy button and LED
TM-2161-0007	Room Command Module, ± setpoint dial, occupancy button and LED, fan speed override
TM-2191-0000	Room Command Module, 54-82°F/12-28°C setpoint dial
TM-2191-0005	Room Command Module, ± setpoint dial

Table 11: Network Room Modules Ordering Information (Available in North America)

Product Code	Features/Options						
	Size, mm (inch)	Service Port Type	LCD Display	Temperature Adjustment Dial	Fan Speed Selector Button	°F/°C Button	Addressable
LP-NRM511-000C	80 x 80 (3.15 x 3.15 in.)	MUI	No	No	No	No	Yes
LP-NRM552-000C			Yes	Yes	No	Yes	No
LP-NRM553-000C			Yes	Yes	Yes	Yes	No
LP-NRM611-000C	120 x 80 (4.72 x 3.15 in.)	MUI	No	No	No	No	Yes
LP-NRM652-000C			Yes	Yes	No	Yes	No
LP-NRM653-000C			Yes	Yes	Yes	Yes	No

Table 12: Medium User Interfaces Ordering Information

Product Code Number	Description
LP-DIS60P20-0C	Medium User Interface (non-isolated version); can be mounted up to 3 m (9.8 ft) from the FX07 and includes panel mounting hardware.
LP-DIS60P21-0C	Medium User Interface (isolated version); can be mounted up to 300 m (1,000 ft) from the FX07 and includes panel and wall mounting hardware.
LP-KIT007-000C	Link cable for the connection of the FX07 to the panel mount MUI – 3 m (9.8 ft).

Technical Specifications

Table 13: FX07 Field Controller Technical Specifications (Part 1 of 3)

Product Codes	LP-FX07xxx-xxx		
Power Requirements	LP-FX07Dxx-xxx: 24 VAC/DC $\pm 15\%$, 50/60 Hz – Safety Extra-Low Voltage (SELV) (Europe) – Class 2 North America LP-FX07Axx-xxx: 90 to 240 VAC, 50/60 Hz (Not available in North America)		
Power Consumption	LP-FX07Dxx-xxx: 9 VA maximum LP-FX07Axx-xxx: 17 VA maximum		
Housing Material	ABS + polycarbonate, self-extinguishing: UL 94-V0 flammability rating		
Protection Class	IP20 CEI/EN60529		
Dimensions (H x W x D)	145 (including terminals) x 108 x 49 mm (62 mm with integral display) 5.71 (including terminals) x 4.26 x 1.93 in. (2.45 in. with integral display)		
Ambient Operating Conditions	-40 to 50°C (-40 to 122°F), 10 to 95% RH (noncondensing) Note that the integral user interface does not operate below -20°C (-4°F).		
Ambient Storage Conditions	-40 to 70°C (-40 to 158°F) 10 to 95% RH (noncondensing)		
Real-Time Clock	Accuracy: Better than ± 200 ms per day at constant ambient temperature of 25°C Backup: Minimum 10 days without power at 25°C		
Power Supply for Panel Mount MUI	15 VDC on remote display connector at 100 mA maximum		
Power Supply Outputs for AIs	15 VDC 20 mA power supply for active sensors (also used for Pulse Width Modulation [PWM] outputs) 5 VDC 15 mA power supply for ratiometric sensors		
Analog Inputs	16-bit resolution – not isolated		
	Sensor Type	Full Linearization Range	Accuracy at 20°C (68°F) Ambient (Sensor Accuracy Not Included)
	A99	-50 to 100°C (-58 to 212°F)	$\pm 0.5^\circ\text{C}$ ($\pm 1^\circ\text{F}$)
	NTC 10k	-40 to 150°C (-40 to 300°F)	$\pm 0.5^\circ\text{C}$ ($\pm 1^\circ\text{F}$)
	Pt 1000 Extended	-50 to 160°C (-58 to 320°F)	$\pm 0.5^\circ\text{C}$ ($\pm 1^\circ\text{F}$)
	Ni 1000 (Johnson Controls)	-45 to 120°C (-49 to 248°F)	$\pm 0.5^\circ\text{C}$ ($\pm 1^\circ\text{F}$)
	Active Voltage	0-10 VDC	± 0.05 VDC
	Active Ratiometric	0.5-4.5 VDC	± 0.05 VDC
Display Range and Resolution	-999 to 999 or -99.9 to 99.9		
Digital (Binary) Inputs	Voltage free contacts Transition counter function at 50 Hz (minimum 10 ms ON and minimum 10 ms OFF)		
Analog Outputs	0-10 VDC, maximum 3 mA, 13-bit resolution - not isolated, accuracy ± 0.1 VDC	For actuating and control devices	
	PWM output at 100 Hz cycle frequency with 10 mA sink from 15 VDC reference power source	For fan speed controllers with PWM input	
Continued on next page . . .			

FX07 Field Controller Technical Specifications (Part 2 of 3)

Relay Outputs	Dielectric test voltage on open relay contact: 1,000 VAC Root Mean Square (RMS) Maximum relay switching rate at maximum load: six operations per minute Average relay contact life: 30,000 operations at maximum load			
Digital (Binary) Outputs for Specific Models	Model	Channel	Type	Remark/Application
	FX07D0x-xxx FX07D5x-xxx FX07A0x-xxx FX07A5x-xxx	DO1, DO2, DO3	Single-Pole, Single-Throw (SPST) 5(3) A, 250 VAC relay Maximum 24 VAC in North America)	Each relay contact is independent with its own common terminal.
		DO4, DO5, DO6	SPST 3(1) A, 250 VAC relay	Each relay contact is independent with its own common terminal. Motor: 0.1 hp, 230 VAC, 0.05 hp, 120 VAC
	FX07D2x-xxx FX07D3x-xxx FX07D7x-xxx FX07D8x-xxx	DO1, DO2	0.5 A/24 VAC triacs	Low voltage 3-point incremental actuators, thermal actuators, for example
	FX07A2x-xxx FX07A3x-xxx FX07A7x-xxx FX07A8x-xxx	DO1, DO2	0.5A/250 VAC triacs	Line voltage 3-point incremental actuators, thermal actuators, for example Can also be used to switch low-voltage 24 VAC devices.
	FX07D2x-xxx FX07D3x-xxx FX07D7x-xxx FX07D8x-xxx FX07A2x-xxx FX07A3x-xxx FX07A7x-xxx FX07A8x-xxx	DO3 DO4 – DO6	SPST 5(3) A, 250 VAC relay (Maximum 24 VAC in North America) SPST 3(1) A, 250 VAC relay	Relay contact is independent with its own common terminal. On the FX07x2x-xxx and FX07x7-xxx models, each relay contact is independent with its own common terminal. On the FX07x3x-xxx and FX07x8-xxx models, DO4, DO5, DO6 relays are physically interlocked so that only one output is closed at one time. Application: 3-speed fan motors. Motor: 0.1 hp, 230 VAC, 0.05 hp, 120 VAC
Connection for Outputs and Power	Screw terminals for maximum 2 x 1.5 mm ² (16 AWG) wires, included in the package			
Connection for Inputs and LON/N2Open/BACnet Networks	Screw terminals for maximum 1 x 1.5 mm ² (16 AWG) wires or 2 x Belden® cable, 2-core twisted pair with shield ≥0.8 mm (20 AWG), included in the package.			
BACnet Compliance	BACnet Testing Laboratories™ (BTL) Listing BACnet Interoperability Building Blocks (BIBBs): BACnet Advanced Application Controller (B-AAC) Protocol Implementation Conformance Statement (PICS) available on request			
Continued on next page . . .				

FX07 Field Controller Technical Specifications (Part 3 of 3)

Agency Compliance	Europe (all models)	<ul style="list-style-type: none"> – 2004/108/EEC, EMC Directive: EN 61000-6-3, EN 61000-6-2 – 2006/95/EEC, Low Voltage Directive: EN 60730
	Canada (LP-FX07Dxx-xxx models only)	<ul style="list-style-type: none"> – UL Listed (PAZX7), C22.2 No. 205, Signal Equipment – Industry Canada, ICES-003
	United States (LP-FX07Dxx-xxx models only)	<ul style="list-style-type: none"> – UL Listed (PAZX), UL 916, Energy Management Equipment – FCC compliant to CFR 47, Part 15, Subpart B, Class A

The performance specifications are nominal and conform to acceptable industry standards. For application at conditions beyond these specifications, consult the local Johnson Controls office. Johnson Controls, Inc. shall not be liable for damages resulting from misapplication or misuse of its products.



Building Efficiency
507 E. Michigan Street, Milwaukee, WI 53202

*Johnson Controls® is a registered trademark of Johnson Controls, Inc.
All other marks herein are the marks of their respective owners. © 2011 Johnson Controls, Inc.*